

Specification



CombiMaster 102 E (10x2/1-20x1/1 GN)

Description	Combi-Steamer (DIN 18866) for most cooking methods employed in the catering trade, with optional use of steam and hot air, separately, sequentially or combined.
Operating modes	Steaming at 100 °C Vario-steaming between 30 °C and 99 °C Cooking in hot air from 30 °C-300 °C Cooking in a combination of hot air and steam from 30 °C-300 °C Finishing 30 °C to 300 °C
Working safety	Maximum rack height 1.60 m when unit installed on an original base cabinet. VDE approved for unsupervised operation.
Function	Cooking by means of freely adjustable convection heat, unpressurised fresh steam or a combination of convection heat and fresh steam.

Features::

- Maximum rack height 1.60 m when original base cabinet used
- Probe for core temperature measurement
- Core temperature probe integral with unit (cannot be lost)
- Demand-related energy supply
- Automatic, active rinsing and drainage of steam generator by pump
- Descaling program
- Integral, maintenance-free grease extraction system with no additional grease filter
- Cool down function for fast cabinet fan cooling
- Integral fan impeller brake
- Rear-ventilated double glass doors, hinged inside pane for easy cleaning
- Door handle with right/left and slam function
- Door locking positions
- Proximity door contact switch
- Seamless hygienic cooking cabinet with rounded corners, cabinet with splash guard - stops water spilling out
- Press-fit cabinet seal
- Airflow optimised cooking cabinet
- Swivel air baffle with quick-release locks
- Drip collector and door drip pan with continuous discharge to unit drain
- Halogen cooking cabinet lighting from shock-proof CERAN glass
- Microprocessor-controlled cooking process
- Buzzer
- Free time selection from 0-24 hours
- Temperature unit adjustable in °C or °F
- Automatic vapour quenching
- Lengthwise loading for 2/1, 1/1 GN accessories
- Hinging rack with additional rail for grease drip container, rail distance 68 mm, hinging rack swivel for easy cleaning
- U-shaped rack rails with notched recesses for easy loading
- All-round heat insulation
- ServiceDiagnostic System with automatic service notices display
- Safety temperature limiter for cabinet and steam generator
- Hinged control panel allows front servicing and inspection
- Operating and warning displays
- DVGW-compliant fixed waste water connection possible
- Separate solenoid valves for normal and soft water
- Height-adjustable feet
- Material inside and out CrNi steel DIN 1.4301
- VDE approved for unsupervised operation
- Hand shower with automatic rewind

Pieces	Unit price	Total price

CombiMaster 102 E (10x2/1-20x1/1 GN)

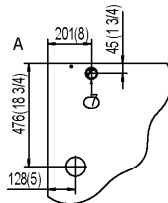
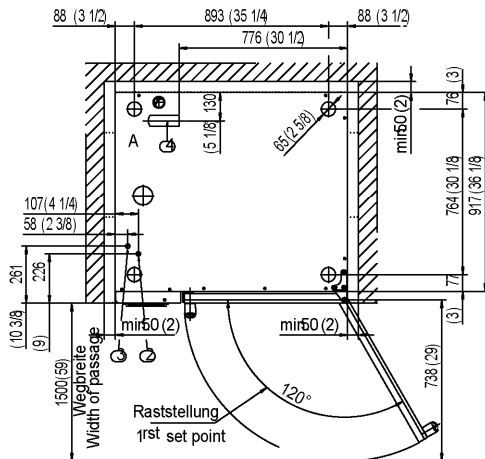
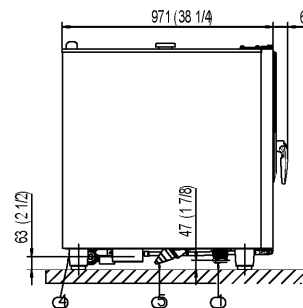
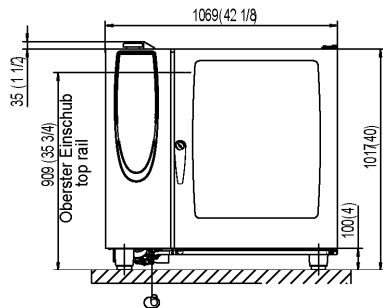

- 1 Common water supply (cold water)
- 2 Water supply cold water
- 3 Water supply soft or hot water
- 4 Drain
- 5 Electrical connection
- 6 Equipotential bonding
- 7 Vent pipe DN 70

Minimum distance 50 mm
Measurements in mm (inches)

Technical specification::

Capacity: 10 x 2/1 GN / 20 x 1/1 GN
Lengthwise loading for: 2/1, 1/1 GN
Number of meals per day: 150-300
Width: 1.069 mm
Depth: 971 mm
Height: 1.017 mm

Water supply (pressure hose): 3/4" / Ø 1/2"
Water pressure (Flow pressure): 150-600 kPa / 0,15-0,6 Mpa / 1,5-6 bar
Water drain: DN 50 mm
Connected load: 40.5 kW
Fuse protection: 3 x 63 A
Mains connection: 3 NAC 415V
"Moist heat" connection: 36 kW

"Dry heat" connection: 36 kW
Weight (net): 175,5 kg
Cable cross-section (Supplied with 2.5 m cable / without connector): 5 x 10 mm²

Marks of conformity: CE, IPX5, VDE, UL, CUL, NSF, KEMA, PCT, GS, DVGW, SVGW, WRAS, KIWA

Option:

- Left-hand hinged doors
- Safety door lock
- Unit with mobile oven rack
- RS 232 serial interface
- RS 485 converter
- Marine version (German Lloyd)
- Security/Prision version
- Can be connected to power optimisation SicoTronic – others upon request
- Special voltages
- Sous vide core temperature probe
- Lockable control panel
- Potential-free contact for status display

Accessories:

- Stands and base cabinets
- Heat shield for left hand side panel
- Grids, containers, trays, CombiFry® (frying baskets)
- Superspike (poultry grid), Griddle grid
- Mobile plate rack
- Transport trolley
- Thermocover
- UltraVent® condensation hood
- Exhaust hood
- CombiLink® software package
- CombiCheck® service package
- Combi-Duo kits for 2 units one on top of the other
- Special Cleaner and Grill Cleaner

RATIONAL AUSTRALIA

Victoria (Head Office)

156 Swann Drive
Derrimut, Vic 3030
Phone: (03) 8369 4600
Fax: (03) 8369 4699

Email: info@rationalaustralia.com.au

New South Wales

Unit 20/4 Avenue of the Americas
Newington NSW 2127
Phone: (02) 9748 3000
Fax: (02) 9648 4762

Email: info@rationalaustralia.com.au

Queensland

1/62 Borthwick Avenue
Murarie, QLD 4172
Phone: (07) 3399 3122
Fax: (07) 3399 5311

Email: info@rationalaustralia.com.au