

CombiMaster 201 G (20x1/1 GN)

Description	Combi-Steamer (DIN 18866) for most cooking methods employed in the catering trade, with optional use of steam and hot air, separately, sequentially or combined.
Operating modes	Steaming at 100 °C Vario-steaming between 30 °C and 99 °C Cooking in hot air from 30 °C-300 °C Cooking in a combination of hot air and steam from 30 °C-300 °C Finishing 30 °C to 300 °C
Working safety	Maximum rack height 1.60 m. VDE approved for unsupervised operation.
Function	Cooking by means of freely adjustable convection heat, unpressurised fresh steam or a combination of convection heat and fresh steam.

Features::

• Maximum rack height 1.60 m • Probe for core temperature measurement • Core temperature probe integral with unit (cannot be lost) • Demand-related energy supply by means of modulating, low-noise high-performance blower burner system • Automatic, active rinsing and drainage of steam generator by pump • Descaling program • Integral, maintenance-free grease extraction system with no additional grease filter • Cool down function for fast cabinet fan cooling • Integral fan impeller brake • Rear-ventilated double glass doors, hinged inside pane for easy cleaning • Cooking cabinet doors with integral sealing mechanism, no steam escape or energy loss when operated without mobile oven rack • Door handle with slam function • Door locking positions • Proximity door contact switch • Seamless hygienic cooking cabinet with rounded corners, cabinet with splash guard - stops water spilling out • Press-fit cabinet seal • Airflow optimised cooking cabinet • Swivel air baffle with quick-release locks • Halogen cooking cabinet lighting from shock-proof CERAN glass • Microprocessor-controlled cooking process • Buzzer • Free time selection from 0-24 hours • Temperature unit adjustable in °C or °F • Automatic vapour quenching • Lengthwise loading for 1/1, 1/2, 2/3, 1/3, 2/8 GN accessories • Mobile oven rack with tandem steering casters, 2 casters with wheel locks, wheel diameter 125 mm, CNS metal parts • Mobile oven rack with locking both sides • Rail distance 63 mm • U-shaped rack rails with notched recesses for easy loading • All-round heat insulation • ServiceDiagnostic System with automatic service notices display • Safety temperature limiter for cabinet and steam generator • Hinged control panel allows front servicing and inspection • Operating and warning displays • DVGW-compliant fixed waste water connection possible • Separate solenoid valves for normal and soft water • Height-adjustable feet • Material inside and out CrNi steel DIN 1.4301 • VDE approved for unsupervised operation • Hand shower with automatic rewind

Pieces	Unit price	Total price
--------	------------	-------------

CombiMaster 201 G (20x1/1 GN)

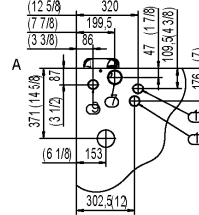
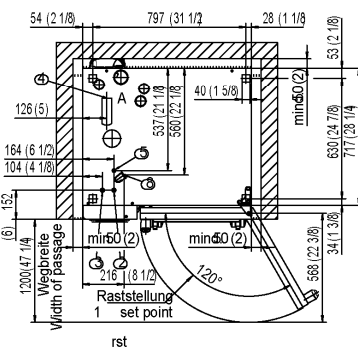
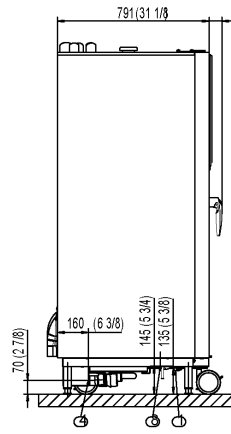
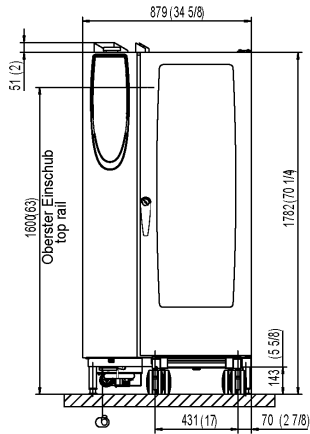

- 1 Common water supply (cold water)
- 2 Water supply cold water
- 3 Water supply soft or hot water
- 4 Drain
- 5 Electrical connection
- 6 Equipotential bonding
- 7 Vent pipe DN 70
- 8 Gas connection 3/4"
- 9 Gas exhaust escape (steam)
- 10 Gas exhaust escape (hot air)

Minimum distance 50 mm
Measurements in mm (inches)

Technical specification::

Capacity: 20 x 1/1 GN
Lengthwise loading for: 1/1, 1/2, 2/3, 1/3, 2/8 GN
Number of meals per day: 150-300
Width: 879 mm
Depth: 791 mm
Height: 1.782 mm
Height incl. gas draft diverter: 2.021 mm
Water supply (pressure hose): 3/4" / Ø 1/2"

Water pressure (Flow pressure): 150-600 kPa / 0,15-0,6 Mpa / 1,5-6 bar
Water drain: DN 50 mm
Electricity connection: 0,7 kW
Weight (net): 261 kg
Fuse protection: 1 x 16 A
Mains connection: 1 NAC 240 V
Cable cross-section (Supplied with 2.5 m cable / without connector): 3 x 2,5 mm²
Gas supply/connection: R3/4"
Exhaust gas duct: A3 (only type 61), B13, B23

Rated thermal load Liquid gas LPG total:
Rated thermal load Liquid gas LPG "Moist heat":
Rated thermal load Liquid gas LPG "Dry heat":
Rated thermal load natural gas total:
Rated thermal load natural gas "Moist heat":
Rated thermal load natural gas "Dry heat":
Marks of conformity: CE, GS, KEMA, DVGW, SVGW, KIWA, IPX5, NSF, GASTEC QA, AGA/CSA, JIA, PCT

Option:

- Safety door lock
- RS 232 serial interface
- RS 485 converter
- Security/Prision version
- Special voltages
- Sous vide core temperature probe
- Lockable control panel
- Potential-free contact for status display
- Unit with mobile oven rack for bakers
- Mobile

Accessories:

- Heat shield for left hand side panel
- Grids, containers, trays, CombiFry® (frying baskets)
- Superspik (poultry grid), Griddle grid
- Mobile plate rack
- Thermocover
- CombiLink® software package
- CombiCheck® service package
- Grease drip container
- Access ramp for mobile oven rack
- Lamb and suckling pig spit
- Draft diverter
- Special Cleaner and Grill Cleaner

RATIONAL AUSTRALIA

Victoria (Head Office)
 156 Swann Drive
 Derrimut, Vic 3030
 Phone: (03) 8369 4600
 Fax: (03) 8369 4699
 Email: info@rationalaustralia.com.au

New South Wales
 Unit 20/4 Avenue of the Americas
 Newington NSW 2127
 Phone: (02) 9748 3000
 Fax: (02) 9648 4762
 Email: info@rationalaustralia.com.au

Queensland
 1/62 Borthwick Avenue
 Murarie, QLD 4172
 Phone: (07) 3399 3122
 Fax: (07) 3399 5311
 Email: info@rationalaustralia.com.au