



# Preinstallation checklist

Company name: _____
Name of contact person: _____
Street: _____
City: _____
Country: _____

Number of RATIONAL units already installed:
Serial number of installed units:
How many units shall be installed?
What type of unit shall be installed?

Please fill in the form either by making a tick in the corresponding box or writing down the measured values in the corresponding lines.



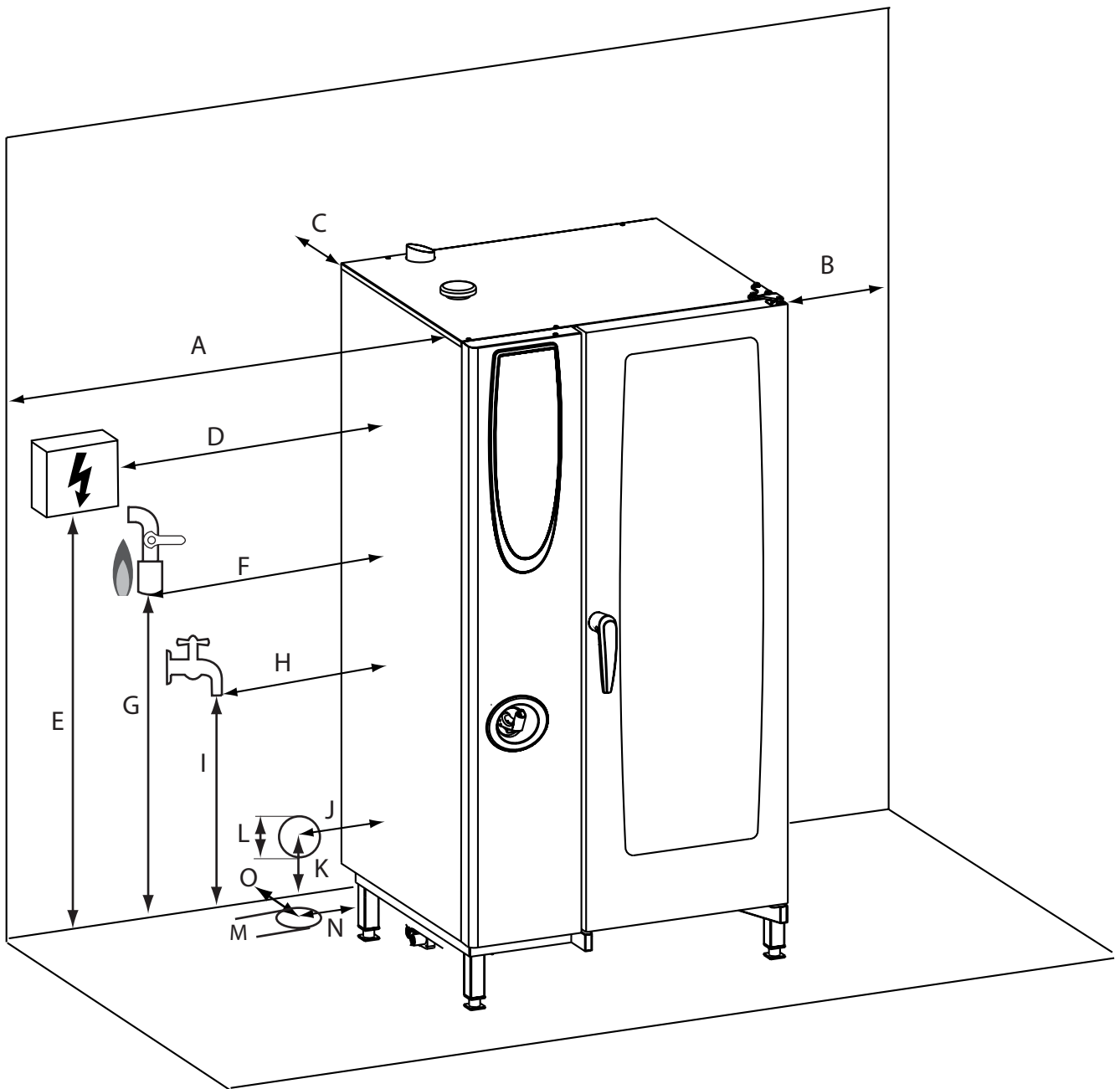

Please fill in values measured at the site:  
 For calculating the distances see unit sizes  
 on page 2.  
 If the connection points are at complete  
 different position show the correct position  
 in the sketch.

**Side distances:**

A =  
 B =  
 C =

**Power supply**

D =  
 E =

**Gas supply (in case of gas units)**

F =

G =

**Type of connection**

**Water supply**

H =

I =

**Drain:**

**Table model**

J =

K =

L =

**Floor model or Combi Duo**

M =

N =

O =

### 3. Water supply

- a) Water filter installed **yes** **no**

If yes, which filters: \_\_\_\_\_  
\_\_\_\_\_

- b) Separate water tap for every unit    
(Attention: Unit has 3/4" connection)

c) Measured water pressure: \_\_\_\_\_

d) Measured water temperature: \_\_\_\_\_

### 4. Drain

- a) Location of drain (fill in page 3)?

c) Material of drain pipe \_\_\_\_\_

Suggestion for drain connection

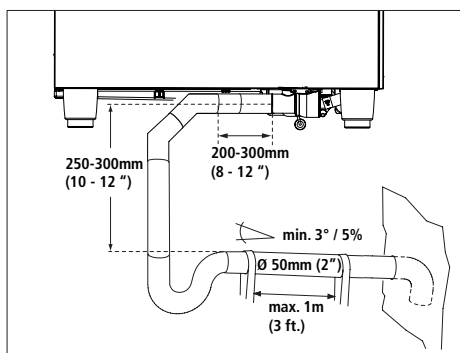
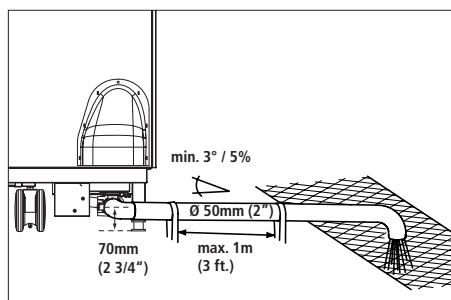

Table model



Floor model

### 5. Gas supply (in case of gas units)

- a) Which gas type is available? \_\_\_\_\_

b) Attention: Unit has 3/4" connection

c) Inform customer to discuss room size and flue gas system with local gas authority

Comments/Notes \_\_\_\_\_

\_\_\_\_\_  
\_\_\_\_\_  
\_\_\_\_\_  
\_\_\_\_\_

\_\_\_\_\_  
Signature Customer

\_\_\_\_\_  
Signature salesman