

Specification



SelfCooking Center® 62 G (6x2/1-12x1/1 GN)

The world's first SelfCooking Center® Just select food, define result - that's it! There is no need for conventional inputs such as temperature, time and humidity, complicated programming, constant monitoring or other routine jobs. All the technical features of the SelfCooking Center® are used fully automatically, which means that you always reap the full benefits for your money. There is simply no need for expensive user training. Even temporary staff can use the SelfCooking Center® without problems.

Description	Cooking appliance for automatically cooking (Automatic mode) roasts, pan fries, poultry, fish, side dishes, potato products, egg dishes, desserts, bakery products and for automatic Finishing®. Hot-air steamer (combi-steamer mode) conforming to DIN 18866 for most of the cooking methods used in commercial kitchens for the optional use of steam and hot air, individually, in succession or in combination.
9 modes of function	Automatic mode: Roasts, pan fries, poultry, fish, side dishes, potato products, egg dishes, desserts, baked products, Finishing®.
3 operating modes	Combi-Steamer mode: Moist heat (steam) between 30 °C and 130 °C Dry heat (hot air) from 30 °C-300 °C Combination of moist heat and dry heat 30 °C-300 °C
Working safety	Maximum rack height 1.60 m when unit installed on an original base cabinet. Detergent and care tabs (solid detergents) for optimum health protection. VDE approved for unsupervised operation.
Function - automatic mode	Function - Automatic mode In the 9 operating modes (Roasts, pan fries, poultry, fish, side dishes, potato products, egg dishes, desserts, baked products, Finishing®) the automatic mode automatically detects product-specific requirements, the size of the food to be cooked and the load size. Cooking time, temperature and the ideal cooking cabinet climate are continuously adjusted to achieve the result you want. The remaining cooking time is displayed.
Function - Combi-Steamer mode	Cooking by means of freely adjustable convection heat, unpressurised fresh steam or a combination of convection heat and fresh steam. In all operating modes cabinet humidity is measured and controlled the exact percentage.

Features::

- Clear control panel with pictograms • Rack monitoring with individual time programming of each rack for non-stop loading • Program memory for at least 350 cooking programs with up to 12 steps • Automatic cleaning and care system for cooking cabinet and steam generator works regardless of the mains pressure • Automatic cleaning prompt that notes the cleaning stage and volume of chemicals • Care status is shown on the display • 6 cleaning stages for unsupervised cleaning and care, even overnight • Detergent and care tabs (solid detergents) for optimum health protection • Maximum rack height 1.60 m when original base cabinet used • Sensor-controlled cabinet humidity, actual humidity in cabinet can be adjusted and requested on the control panel • 5 air speeds, programmable • Humidifying function can be programmed with humidity values from 30 °C-260 °C for Dry Heat and Combination • Core temperature probe with 6 measuring points and automatic correction if inserted incorrectly • Core temperature probe integral with unit (cannot be lost) • Positioning aid for core temperature probe • Demand-related energy supply by means of modulating, low-noise high-performance blower burner system • Integral hand shower with infinitely variable regulation, automatic retracting system and integral water shut-off function • High-performance fresh steam generator with automatic self-cleaning system prevents the development of limescale; soft water and regular descaling are not required. • Level of scaling in the steam generator is monitored and displayed. • Automatic, active rinsing and drainage of steam generator by pump • Limescale level of steam generator automatically sensed, automatic indication of when descaling is necessary, limescale level displayed at any time • Menu-guided descaling program • Integral, maintenance-free grease extraction system with no additional grease filter • Cool down function for fast cabinet fan cooling • Integral fan impeller brake • Rear-ventilated double glass doors, hinged inside pane for easy cleaning • Door handle with right/left and slam function • Door locking positions • Proximity door contact switch • Seamless hygienic cooking cabinet with rounded corners, cabinet with splash guard - stops water spilling out • Press-fit cabinet seal • Airflow optimised cooking cabinet • Swivel air baffle with quick-release locks • Drip collector and door drip pan with continuous discharge to unit drain • Halogen cooking cabinet lighting from shock-proof CERAN glass • Microprocessor-controlled cooking process • HACCP data memory and output via integral USB interface • Adjustable buzzer tone • Adjustable foreign languages display • Adjustable display contrast • Real time display • Free time selection from 0-24 hours, can be adjusted in hours/minutes or minutes/seconds • Preselected starting time adjustable for time and date • Function Delta-T cooking • Temperature unit adjustable in °C or °F • Automatic vapour quenching • Lengthwise loading for 2/1, 1/1 GN accessories • Hinging rack with additional rail for grease drip container, rail distance 68 mm, hinging rack swivel for easy cleaning • U-shaped rack rails with notched recesses for easy loading • All-round heat insulation • ServiceDiagnostic System with automatic service notices display • Safety temperature limiter for cabinet and steam generator • Hinged control panel allows front servicing and inspection • Operating and warning displays • DVGW-compliant fixed waste water connection possible • Separate solenoid valves for normal and soft water • Height-adjustable feet • Material inside and out CrNi steel DIN 1.4301 • VDE approved for unsupervised operation

Pieces	Unit price	Total price

SelfCooking Center® 62 G (6x2/1-12x1/1 GN)

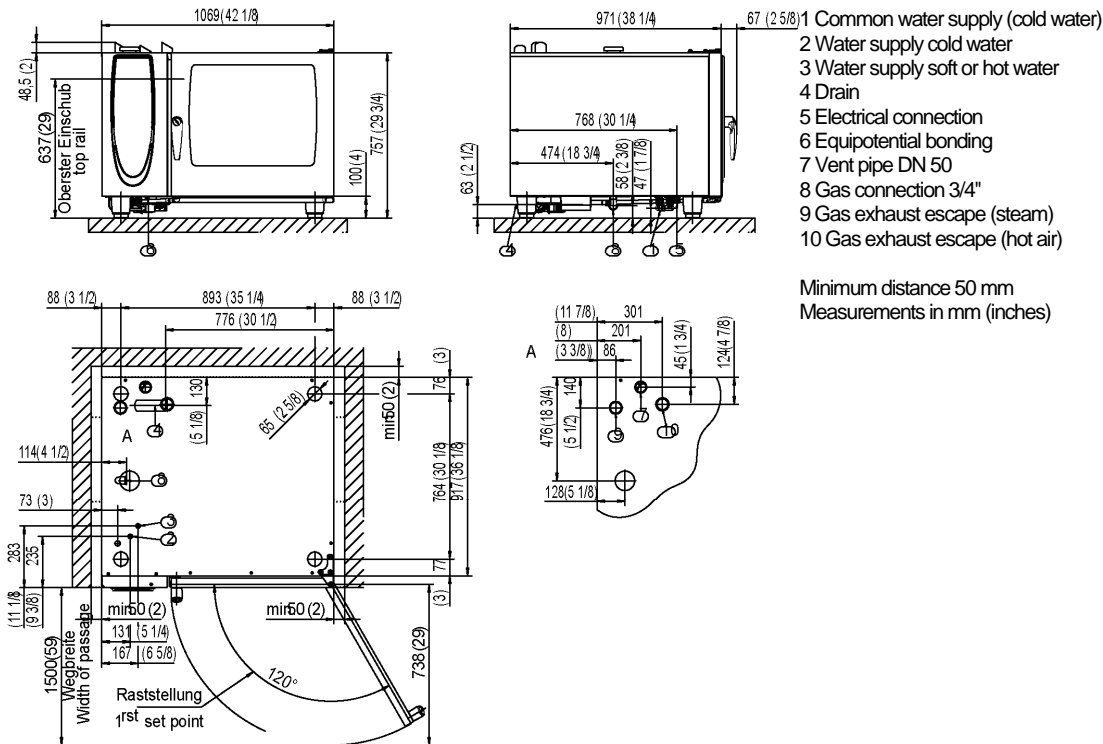

Technical specification:

Capacity:	6 x 2/1 GN
Lengthwise loading for:	2/1, 1/1 GN
Number of meals per day:	60-160
Width:	1.069 mm
Depth:	971 mm
Height:	757 mm
Height incl. gas draft diverter:	996 mm
Water supply (pressure hose):	3/4" / Ø 1/2"

Water pressure (Flow pressure):	150-600 kPa / 0,15-0,6 Mpa / 1,5-6 bar
Water drain:	DN 50 mm
Electricity connection:	0,4 kW
Weight (net):	168 kg
Fuse protection:	1 x 16 A
Mains connection:	1 NAC 240 V
Cable cross-section (Supplied with 2.5 m cable / without connector):	3 x 2,5 mm ²
Gas supply/connection:	3/4"
Exhaust gas duct:	A3 (only type 61), B13, B23

Rated thermal load Liquid gas LPG total:	82,8 MJ
Rated thermal load Liquid gas LPG "Moist heat":	75,6 MJ
Rated thermal load Liquid gas LPG "Dry heat":	82,8 MJ
Rated thermal load natural gas total:	77,4 MJ
Rated thermal load natural gas "Moist heat":	72,0 MJ
Rated thermal load natural gas "Dry heat":	77,4 MJ
Marks of conformity:	CE, GS, KEMA, DVGW, SVGW, KIWA, IPX5, NSF, GASTEC QA, AGA/CSA, JIA, PCT

Option:

- Left-hand hinged doors
- Safety door lock
- Unit with mobile oven rack
- RS 232 serial interface
- RS 485 converter
- Ethernet interface
- Security/Prision version
- Integral fat drain
- Special voltages
- Sous vide core temperature probe
- Menu pad
- Lockable control panel
- Potential-free contact for status display

Accessories:

- Stands and base cabinets
- Heat shield for left hand side panel
- Grids, containers, trays, CombiFry® (frying baskets)
- Superspike (poultry grid), Griddle grid
- Mobile plate rack
- Transport trolley
- Thermocover
- CombiLink® software package
- CombiCheck® service package
- Combi-Duo kits for 2 units one on top of the other
- Special Cleaner tablets and Rinse Aid tablets
- Draft diverter

RATIONAL AUSTRALIA

Victoria (Head Office)
156 Swann Drive
Derrimut, Vic 3030
Phone: (03) 8369 4600
Fax: (03) 8369 4699
Email: info@rationalaustralia.com.au

New South Wales
Unit 20/4 Avenue of the Americas
Newington NSW 2127
Phone: (02) 9748 3000
Fax: (02) 9648 4762
Email: info@rationalaustralia.com.au

Queensland
1/62 Borthwick Avenue
Murarie, QLD 4172
Phone: (07) 3399 3122
Fax: (07) 3399 5311
Email: info@rationalaustralia.com.au